

BF2500A 540x1150mm 2500Kg



■ **Premium Pump Unit**

Heavy duty 2500kg Capacity low maintenance pump unit with 10 pump stroke to max lift height

■ **Double Rollers and Guide Rollers**

Polyurethane Double fork rollers and steer wheels fitted as standard



1000's of Trucks in stock Available in 3 colours



■ **Three position Handle**
(Pump / Neutral / Release)
with Comfort grip handle



■ **Certificate of Conformity**

All our trucks are CE / UK CA certified & come with a certificate of conformity

Model			BF2500A
capacity		kg	2500
pump type			BF
wheel (drive/load) type			Polyurethane
size of steering wheel	ΦD	mm	180*50
size of loading wheel (double wheel)	Φd	mm	80*70
max. fork height	H	mm	205
min. fork height	H1	mm	85
fork outer width	W	mm	540
fork length	L	mm	1150
overall length	N	mm	1550
overall height	R	mm	1230
A frame height	T	mm	460
fork width	S	mm	160
steel thickness (after painting)		mm	3
weight		kg	72

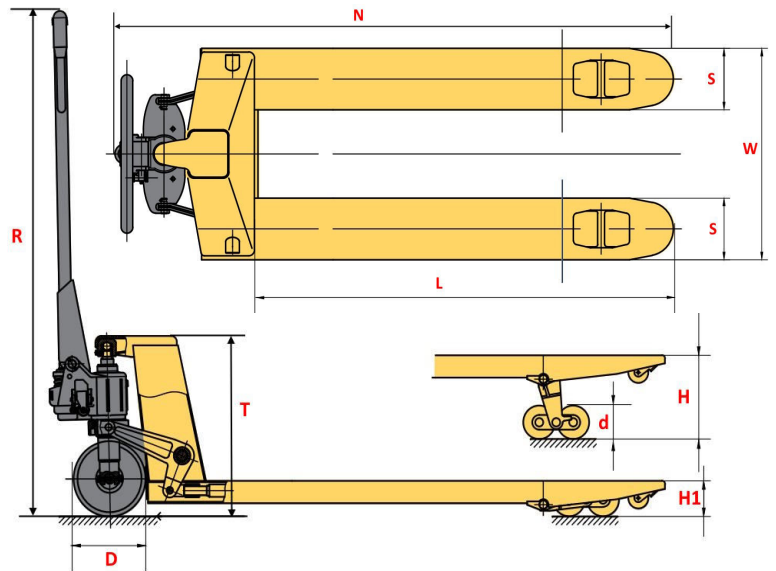

With dimensions over the forks of **540x1150mm**, this is the ideal size for the most common **Euro Pallets of 120x80cm**, but will also lift the common **GKN/Chep pallets of 120x100cm** and many other sizes.

The frames are made from a **heavy grade steel construction** and finished in an **epoxy powder coated paint** that offers greater **Anticorrosion resistance**.



Next Day Delivery
Available



Spare Parts & Technical
Support